

CAPACITY	SYMBOL/ SERIAL NO.	CIRCUIT DIAGRAM
AC100-240V, 50/60Hz		
5W		

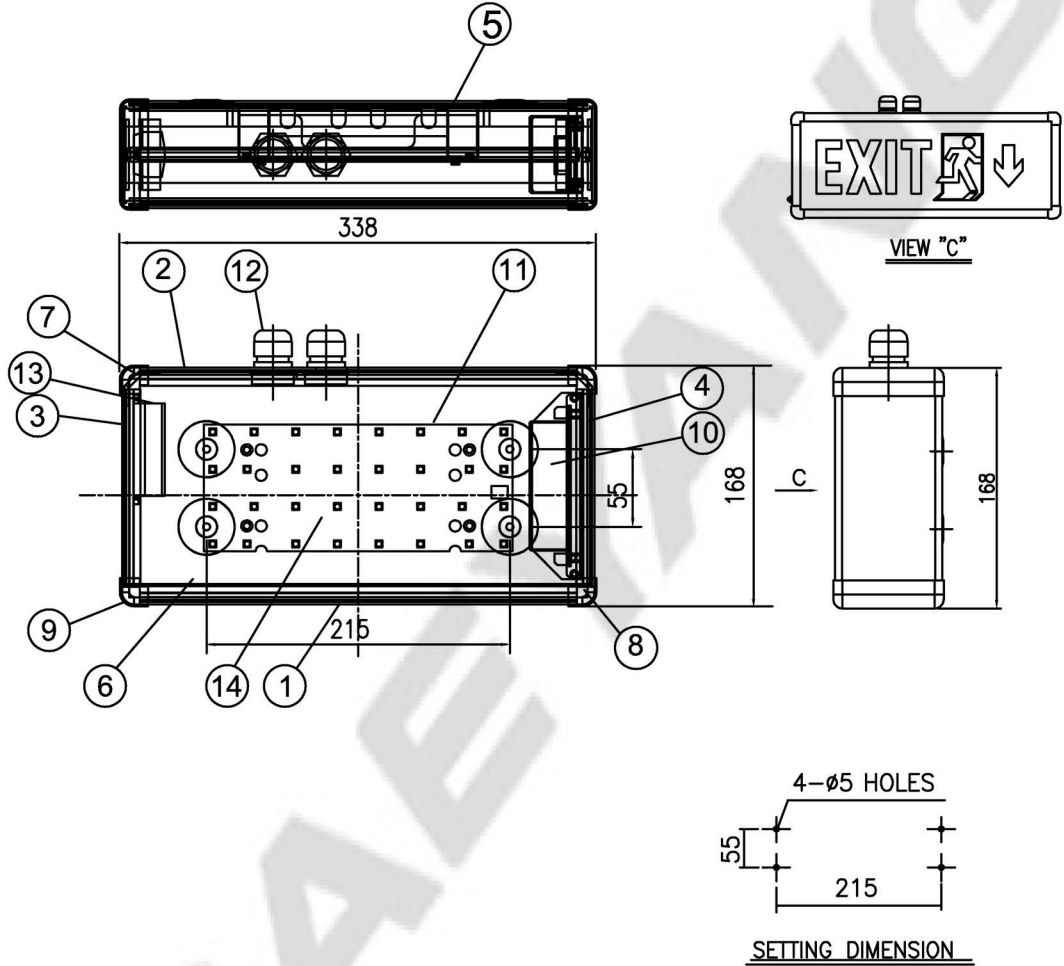

14	LED module	-	1		7	UPPER BRACKET	ALUMINIUM	2	
13	TERMINAL BLOCK	-	1	CLAMPING 5P	6	SIGN COVER	ACRYL	1	
12	CABLE GLAND(PG16)	-	2	ø12~ø16	5	REAR COVER	STEEL	1	
11	LED module BRACKET	STEEL	1		4	RIGHT BODY	ALUMINIUM	1	
10	LED driver CASE	STEEL	1		3	LEFT BODY	ALUMINIUM	1	
9	SIDE COVER	POLYCAR-BONATE	4		2	UPPER BODY	ALUMINIUM	1	
8	LOWER BRACKET	ALUMINIUM	2		1	LOWER BODY	ALUMINIUM	1	
NO	NAME OF PARTS	MATERIAL	Q'TY	REMARKS	NO	NAME OF PARTS	MATERIAL	Q'TY	REMARKS

APPROVED	B. K. KIM	UNIT	MM	TITLE; LED EXIT LIGHT (SURFACE TYPE) FOR MARINE USE			
CHECKED		SCALE	N/S				
DRAWING	B. I. KIM	COLOR	N-9.3				
DATE	2018.11.09	IP	44				
				MODEL NO.	LEXIT105SS-0550A-EMD	WEIGHT	3.4 Kg
				DWG NO.	L05110024	SHEET NO.	39

NO	CONTENT	DATE	REVISER	APPROVAL
△				
△				
△				

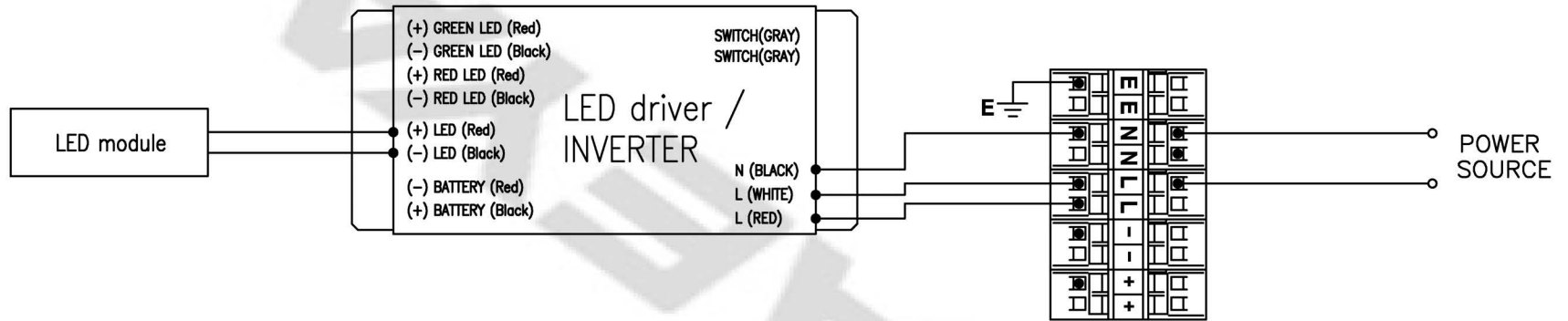

TITLE: LEXIT105SS-0550A-EMD		SCALE	N/S	UNIT	MM	NO.	REVISED
CIRCUIT DIAGRAM						△	
PROJECT METHOD		WEIGHT		KG		△	
APPROVED	B. K. KIM					△	
CHECKED						MATERIAL	ASSY
DRAWN	B. I. KIM					DWG NO.	
DATE	2018.11.09					SHEET NO.	39-A